

**PRODUCT DATA SHEET**

PAGE 1/2

Stainless steel flush-mounting wall distributor

Item no. MS62100011

**TECHNICAL DATA**

Dimensions:	420x212x580mm (WxDxH)
Ingress protection:	IP44
Protection class:	I
Material:	V2A stainless steel (1.4301)
Color:	Visible sides polished (K240)
Equipment:	2 x Protective contact socket 16A 2P+E 230V 1 x CEE 16A 5P 400V 1 x CEE 32A 5P 400V 2 x MCB 16A C 1P 1 x MCB 16A C 3P 1 x MCB 32A C 3P 1 x RCD 63/0,03A 4P
max. back-up fuse:	63A
Cable inlet:	2 x above, 2 x below with grommets for cable diameters up to 36mm
Power supply terminals:	5x25qmm
Weight:	approx. 22kg



## PRODUCT DATA SHEET

PAGE 2/2

### DIMENSIONS

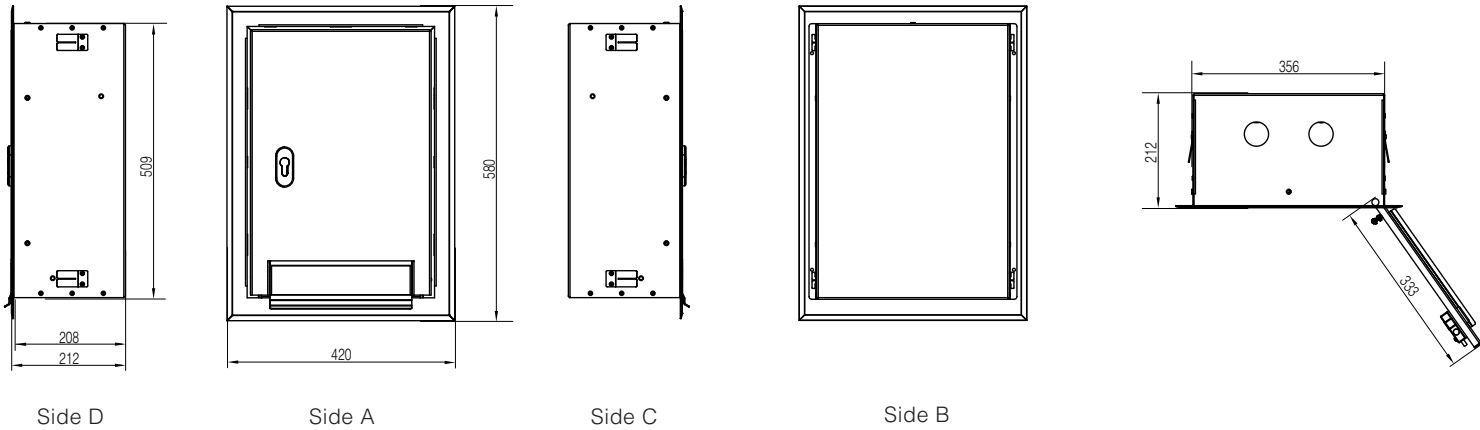

All dimensions in millimeter.

### WIRING DIAGRAM

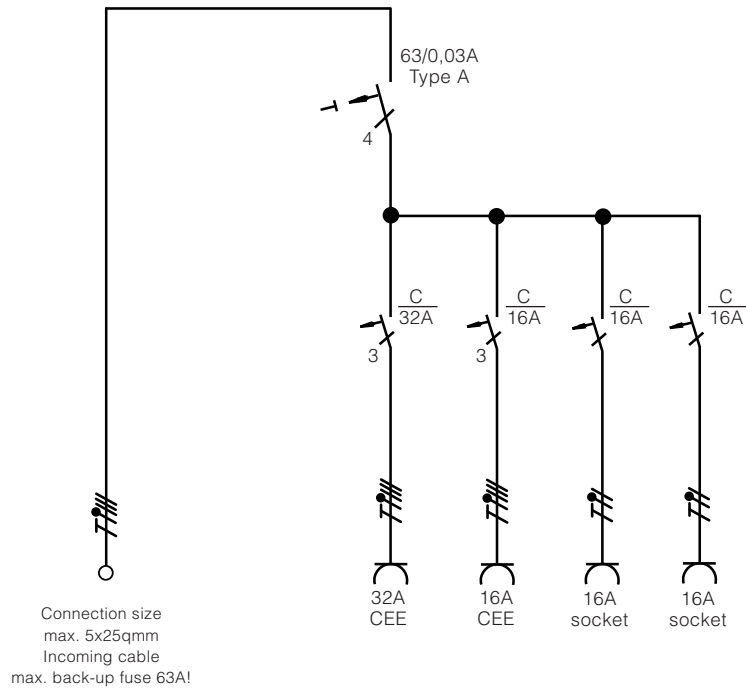

Modifications and errors excepted. No liability accepted for printing errors.  
Our terms of delivery and payment apply.