



MOSER SYSTEMELEKTRIK GMBH

CONNECTION COLUMNS ENERGY BOLLARDS
UNDERGROUND DISTRIBUTORS STANDING CABINETS
KERNERSTRASSE 15 74405 GAILDORF GERMANY

PRODUCT DATA SHEET

PAGE 1/2

MSR12 Light column
Item no. MM90300001C



TECHNICAL DATA

Dimensions:	120x300mm (DxH)
Ingress protection:	IP44
Protection class:	I
Material:	Aluminum, anodized E6/EV1
Color:	anthracite
max. back-up fuse:	16A
Light module:	LED Mounting light - Lamp holder E27 - Light source: LED-Lampe 9W, 220V, daylight white ~6.000K - pre-wired on connection clamps 3x4qmm
Weight:	approx. 3,5kg



PRODUCT DATA SHEET

PAGE 2/2

DIMENSIONS

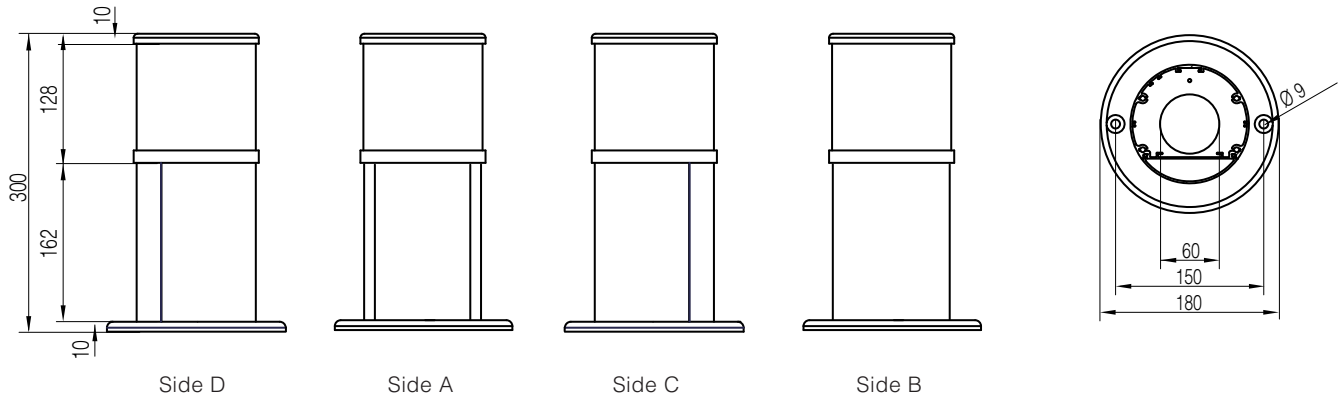

All dimensions in millimeters.

WIRING DIAGRAM



Modifications and errors excepted. No liability accepted for printing errors.
Our terms of delivery and payment apply.