



MOSER SYSTEMELEKTRIK GMBH

CONNECTION COLUMNS ENERGY BOLLARDS
UNDERGROUND DISTRIBUTORS STANDING CABINETS
KERNERSTRASSE 15 74405 GAILDORF GERMANY

PRODUCT DATA SHEET

PAGE 1/1

MS18 Ground element

Item no. MD10100004



TECHNICAL DATA

Dimensions:	180x100x508mm (WxDxH)
Material:	Aluminum, anodized E6/EV1
Color:	silver
Mounting material:	4 x Countersunk screw M8x20 A2 4 x Countersunk screw M6x25 A2
Weight:	approx. 3,6kg

DIMENSIONS

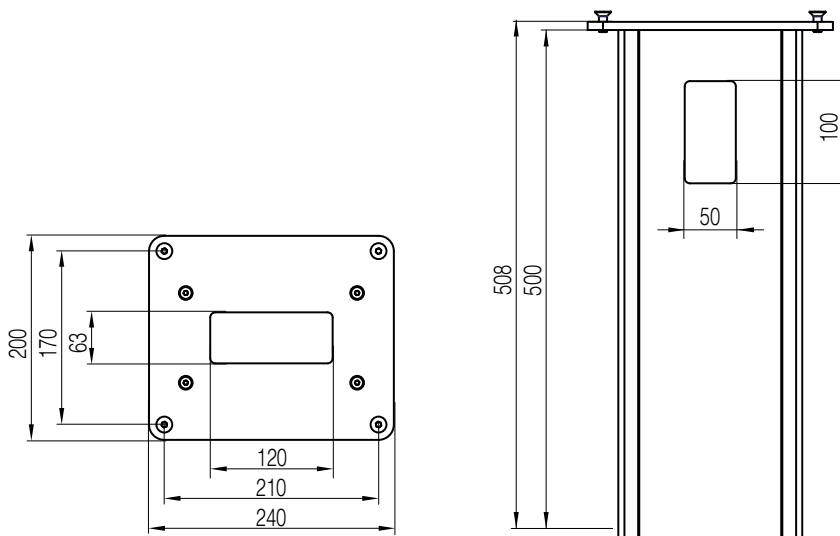

All dimensions in millimeters.

Modifications and errors excepted. No liability accepted for printing errors.
Our terms of delivery and payment apply.