



PRODUCT DATA SHEET

PAGE 1/1

MS10 Supporting flange

Item no. MB10700014C



TECHNICAL DATA

Dimensions:	180x140x90mm (WxDxH)
Material:	Cast aluminum
Color:	anthracite
Mounting material:	4 x Screw M5x25 A2 (for fastening the base plate to the column profile) 4 x Screw M5x16 A2 (for fastening the supporting flange with the press-on flange) 4 x Chipboard screw M8x60 A2 4 x Dowel S12
Weight:	approx. 1,3kg

DIMENSIONS

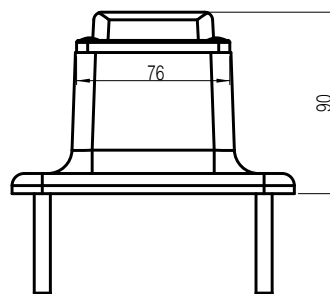
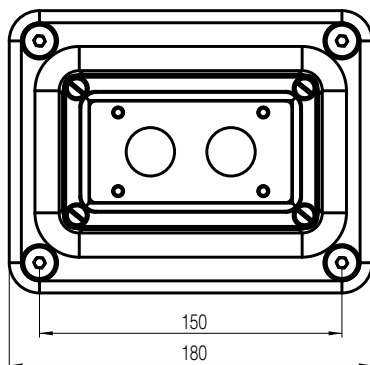

All dimensions in millimeters.