



PRODUCT DATA SHEET

PAGE 1/2

SEK20 - compact underfloor distributor

Item no. M5062000013

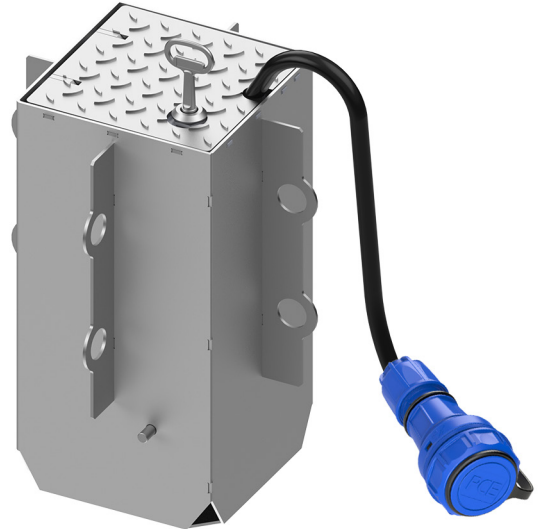

TECHNICAL DATA

Dimensions:	200x200x400mm (LxWxD)
Installation depth:	400mm
Dimensions visible cover:	187x190mm (LxW)
Load capacity:	25t DIN EN 124 - C250
Material:	V2A stainless steel (1.4301)
Interlocking:	by sash lock (square)
Drainage:	via four recesses in the lower part of the housing
Ingress protection:	IP68 (socket coupling)
Protection class:	I
Equipment:	1 x Protective contact coupling 16A 2P+E 230V
max. back-up fuse:	16A
Power supply terminals:	3x2,5qmm
Weight:	approx. 15kg



PRODUCT DATA SHEET

PAGE 2/2

DIMENSIONS

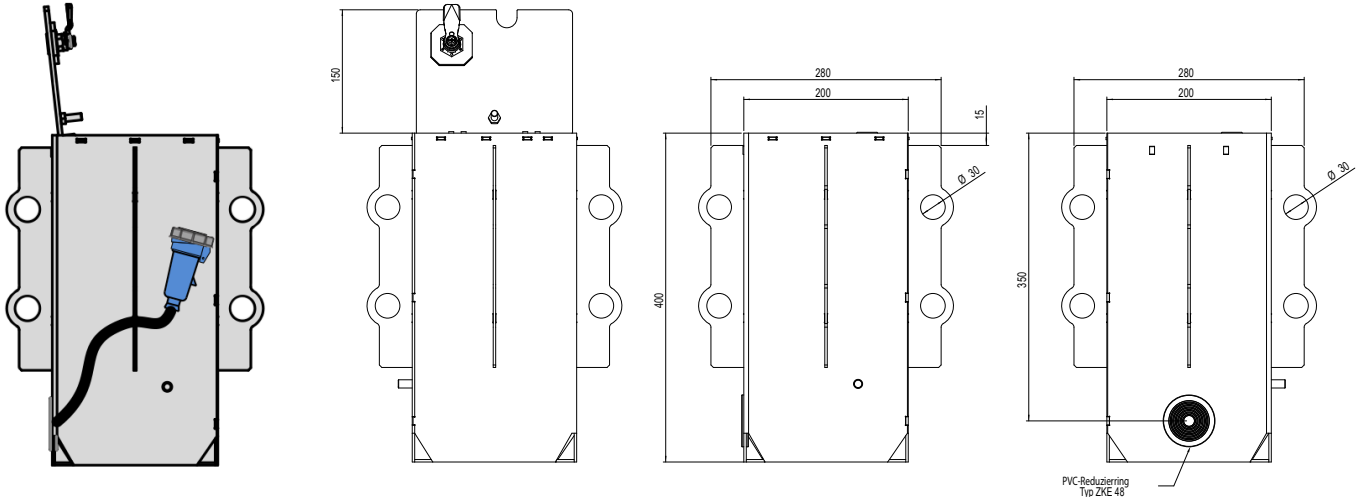

All dimensions in millimeters.

WIRING DIAGRAM

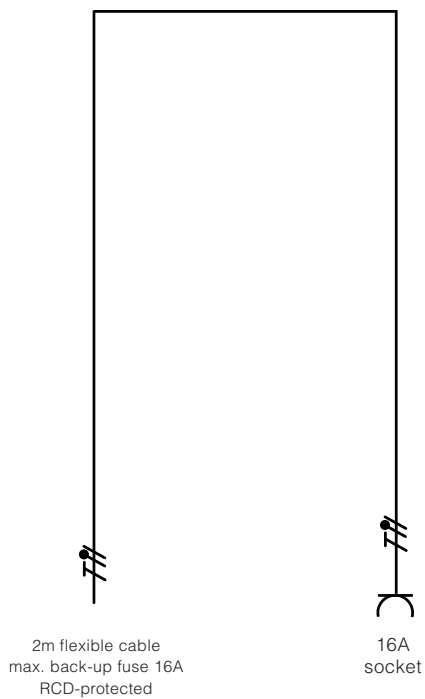

Modifications and errors excepted. No liability accepted for printing errors.
Our terms of delivery and payment apply.