



## PRODUCT DATA SHEET

PAGE 1/2

SEK80 - Underfloor distributor with hinged cover

Item no. M5048100003



### TECHNICAL DATA

Dimensions:	880x630x650mm (LxWxD)
Installation depth:	650mm
Dimensions visible cover:	800x550mm (LxW)
Load capacity:	1,5t DIN EN 124 - A15
Material:	V2A stainless steel (1.4301)
Interlocking:	via locking system incl. actuation key
Drainage:	on site through pipe socket Ø108mm to the local sewerage system
Ingress protection:	depending on the equipment
Protection class:	I
Equipment:	Empty housing, without equipment
Weight:	approx. 95kg



**PRODUCT DATA SHEET**  
PAGE 2/2

**DIMENSIONS**

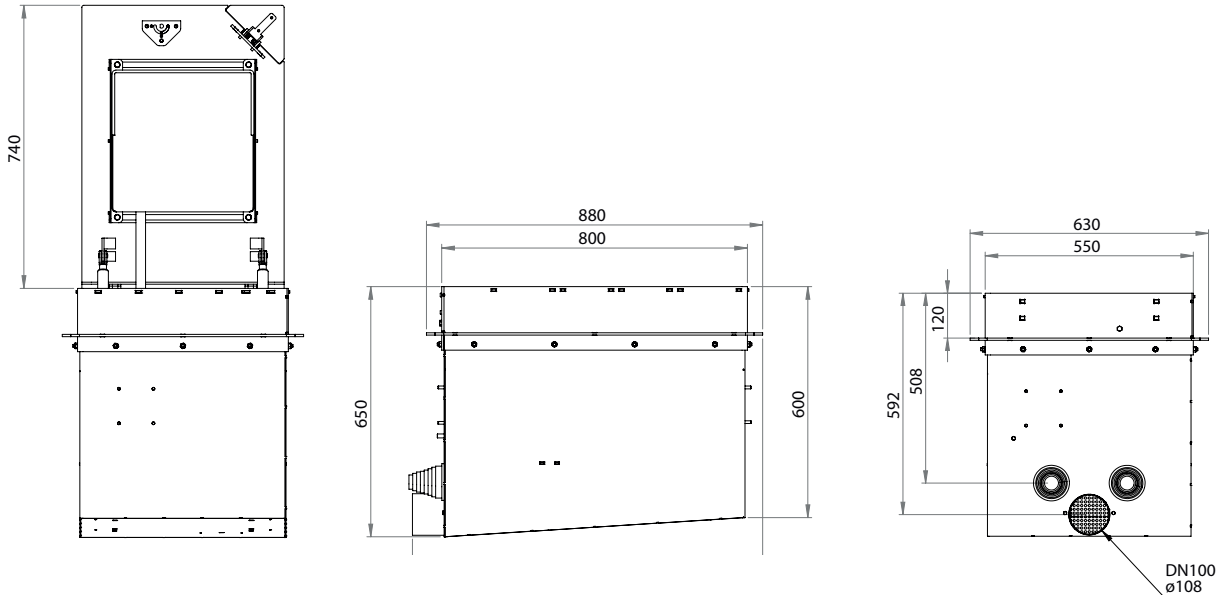

All dimensions in millimeters.

Modifications and errors excepted. No liability accepted for printing errors.  
Our terms of delivery and payment apply.