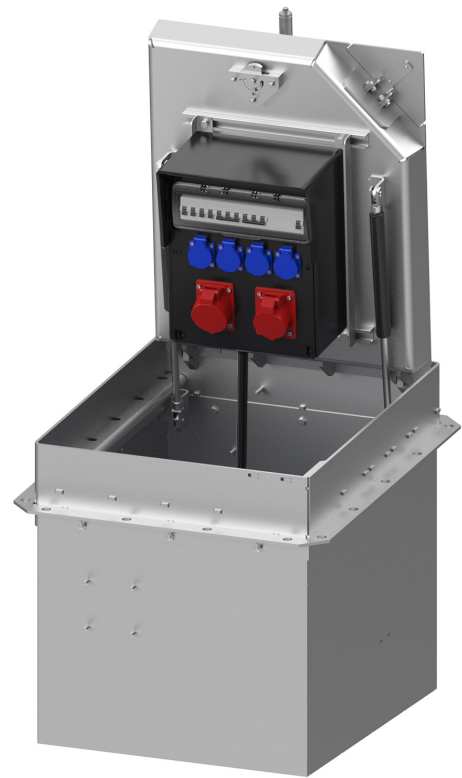

**PRODUCT DATA SHEET**

PAGE 1/2

SEK70 - Underfloor distributor with hinged cover

Item no. M5047000043

**TECHNICAL DATA**

Dimensions:	780x630x650mm (LxWxD)
Installation depth:	650mm
Dimensions visible cover:	700x550mm (LxW)
Load capacity:	12,5t DIN EN 124 - B125
Material:	V2A stainless steel (1.4301)
Interlocking:	via locking system incl. actuation key
Drainage:	on site through pipe socket Ø108mm to the local sewerage system
Ingress protection:	IP54
Protection class:	I
Equipment:	4 x Protective contact socket 16A 2P+E 230V 1 x CEE 16A 5P 400V 1 x CEE 32A 5P 400V 3 x MCB 16A C 1P 1 x MCB 16A C 3P 1 x MCB 32A C 3P 1 x RCD 63/0,03A 4P (additionally: 1 x MCB 6A B 1P for the heating - optionally available) 1 x Drinking water connection 3/4"
max. back-up fuse:	50A
Power supply terminals:	5x25qmm
Weight:	approx. 130kg



PRODUCT DATA SHEET

PAGE 2/2

DIMENSIONS

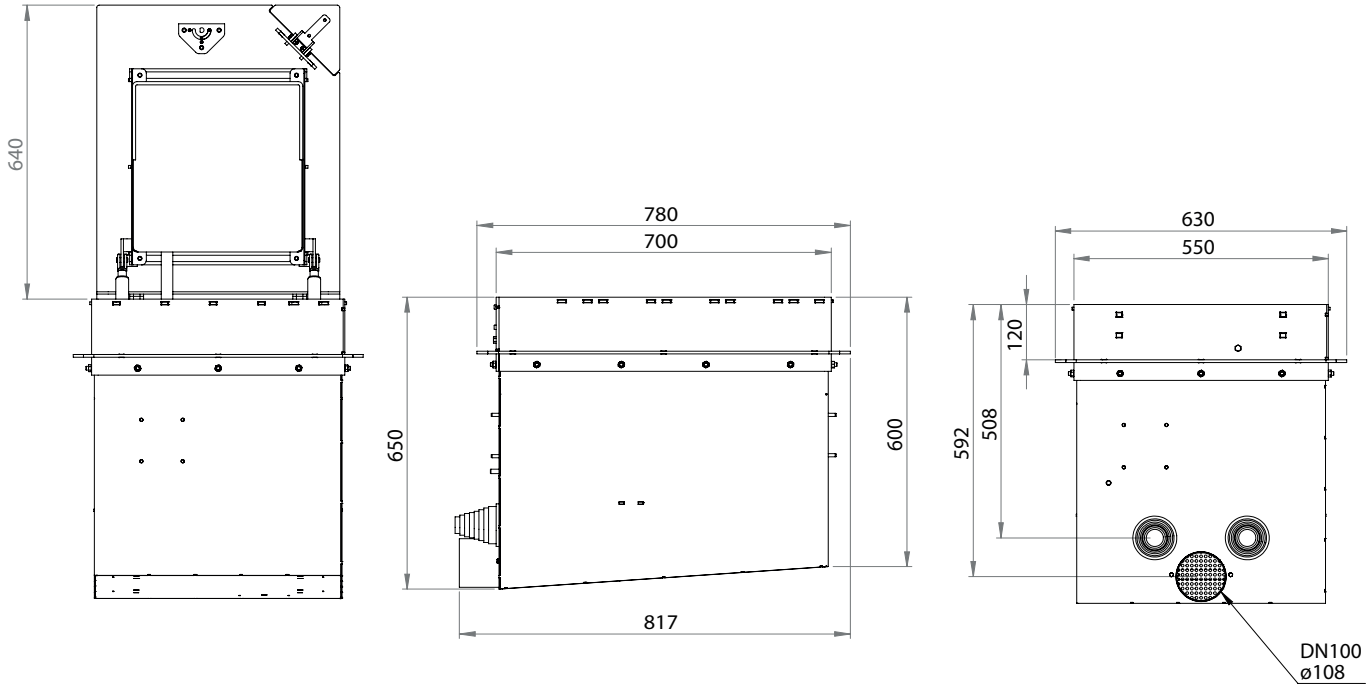

WIRING DIAGRAM

All dimensions in millimeters.

