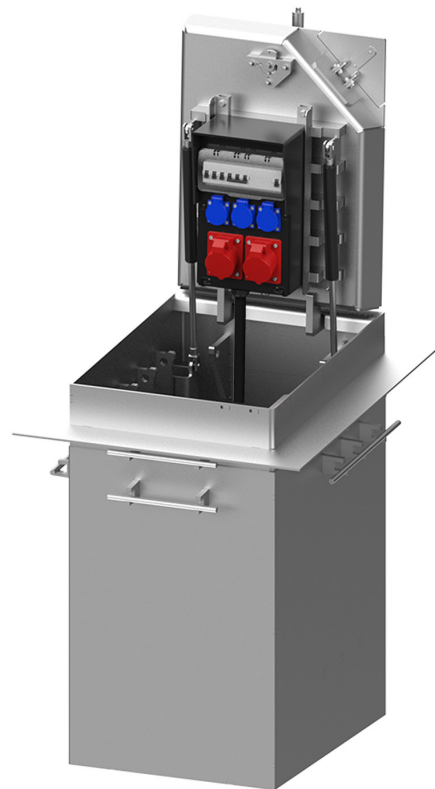

**PRODUCT DATA SHEET**

PAGE 1/2

SEK60 - Underfloor distributor with hinged cover

Item no. M5046400033

**TECHNICAL DATA**

Dimensions:	850x648x900mm (LxWxD)
Installation depth:	900mm
Dimensions visible cover:	662x460mm (LxW)
Load capacity:	40t DIN EN 124 - D400
Material:	V2A stainless steel (1.4301)
Interlocking:	via locking system incl. actuation key
Drainage:	on site through pipe socket Ø108mm to the local sewerage system
Ingress protection:	IP54
Protection class:	I
Equipment:	3 x Protective contact socket 16A 2P+E 230V 2 x CEE 16A 5P 400V 2 x MCB 16A C 1P 1 x MCB 16A C 3P 1 x RCD 63/0,03A 4P (additionally: 1 x MCB 6A B 1P for the heating - optionally available)
max. back-up fuse:	32A
Power supply terminals:	5x10qmm
Weight:	approx. 185kg



PRODUCT DATA SHEET

PAGE 2/2

DIMENSIONS

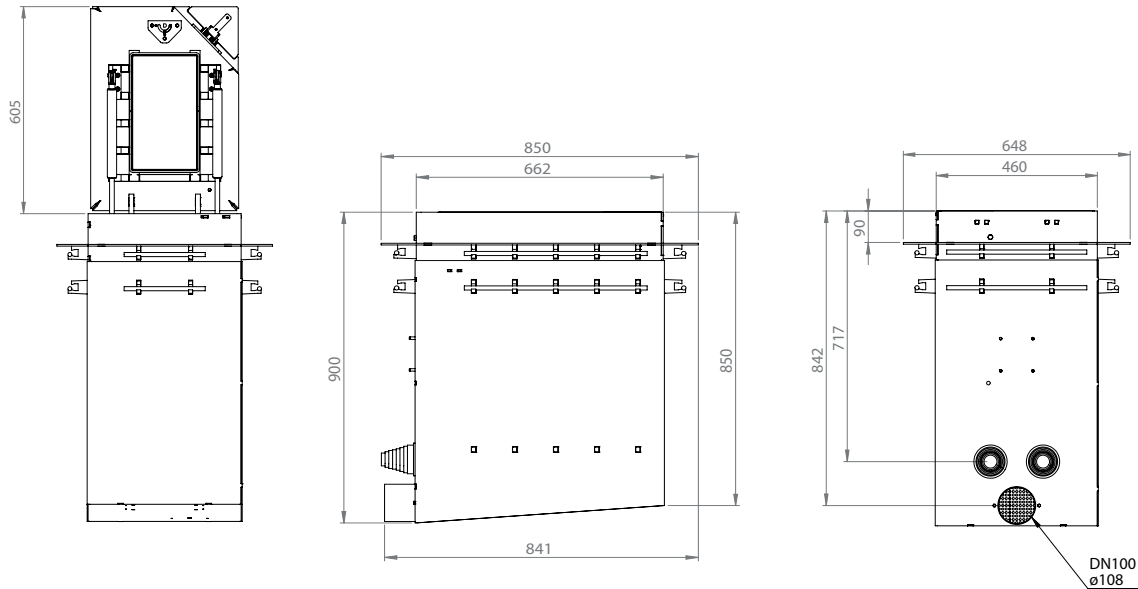

All dimensions in millimeters.

WIRING DIAGRAM

