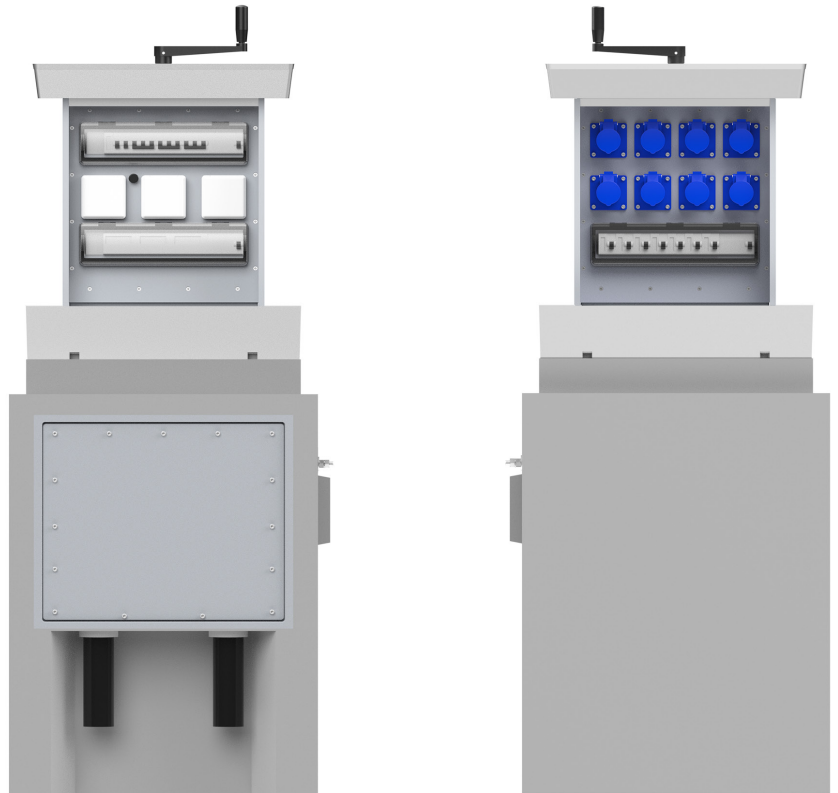

**PRODUCT DATA SHEET**

PAGE 1/2

SE56 - Retractable supply post

Item no. M5035632020

**TECHNICAL DATA**

Dimensions:	965x632x928mm (HxWxL)
Installation depth:	1075mm
Extending height:	520mm
Load capacity:	40t DIN EN 124 - D400
Material:	Cast aluminum, Aluminum, PVC, Concrete
Drainage:	via integrated drainage system in concrete shaft
Heating:	Heating device 20W for condensation reduction incl. T2A fine wire fuse
Ingress protection:	IP44: Sockets / IP54: Distribution modules
Protection class:	I
Equipment:	8 x CEE 16A 3P 230V 2 x CEE 16A 5P 400V 1 x CEE 32A 5P 400V 8 x MCB 16A C 1P 2 x MCB 16A C 3P 1 x MCB 32A C 3P 2 x RCD 63/0,03A 4P 8 x Single phase energy meter 3 x Three phase energy meter
max. back-up fuse in the pit:	NH-000 63A
Power supply terminals:	5x50qmm
Weight:	approx. 730kg



MOSER SYSTEMELEKTRIK GMBH

CONNECTION COLUMNS ENERGY BOLLARDS
UNDERGROUND DISTRIBUTORS STANDING CABINETS
KERNERSTRASSE 15 74405 GAILDORF GERMANY

PRODUCT DATA SHEET

PAGE 2/2

DIMENSIONS

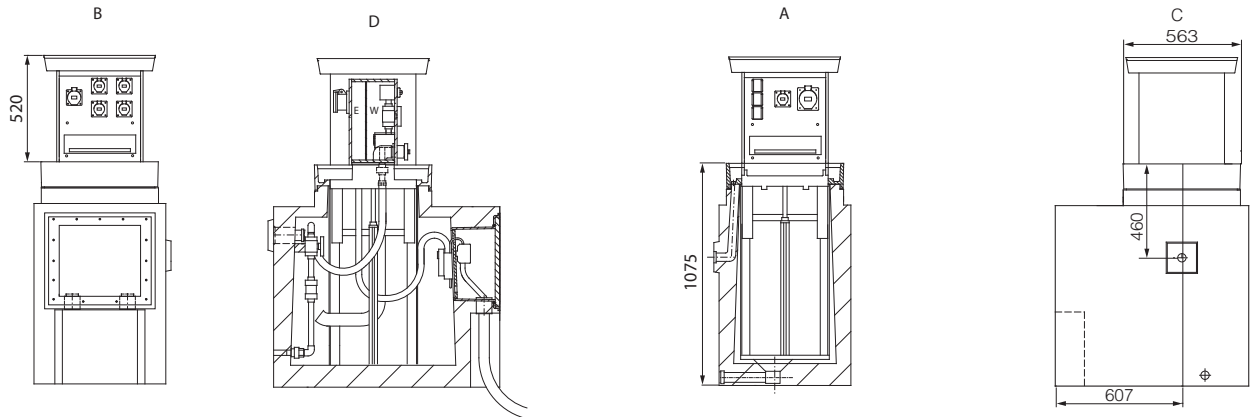

All dimensions in millimeters.

WIRING DIAGRAM

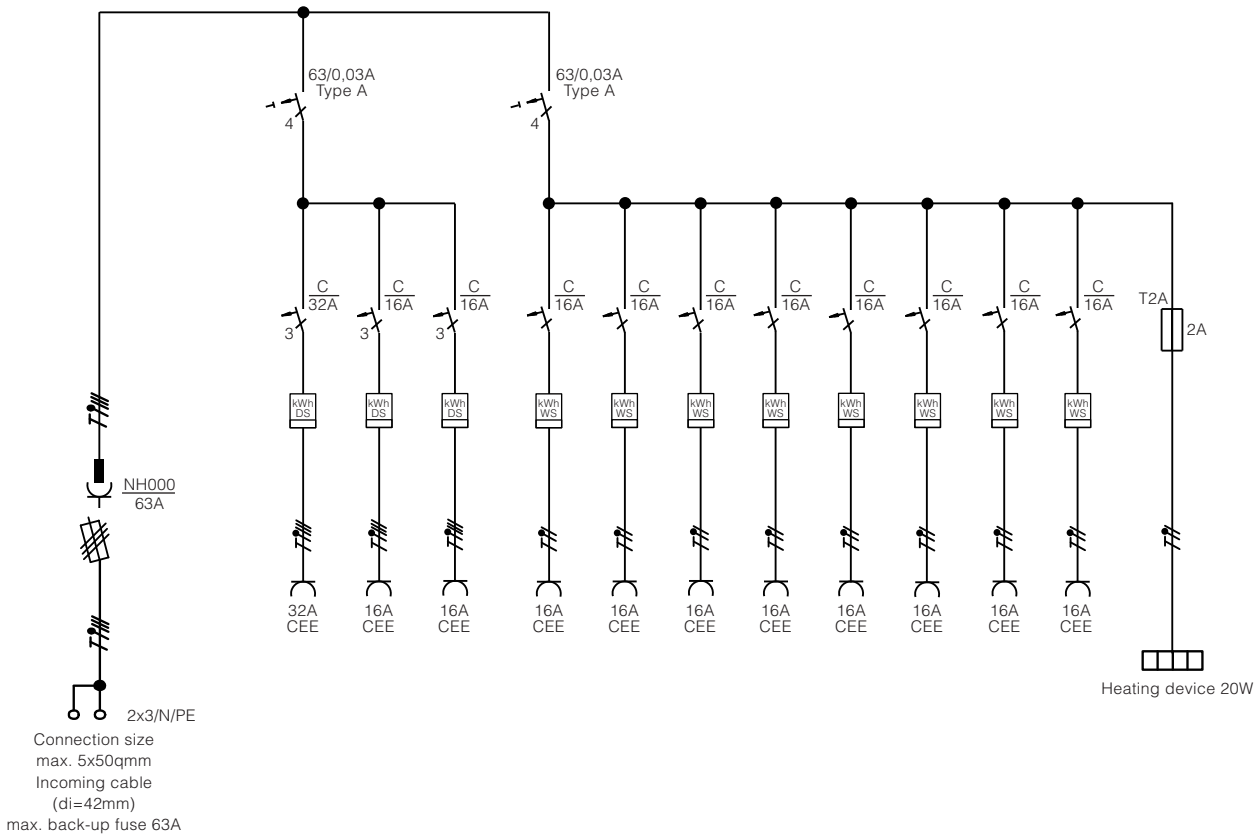

Modifications and errors excepted. No liability accepted for printing errors.
Our terms of delivery and payment apply.