



PRODUKTDATENBLATT

SEITE 1/1

MSR12 Erdstück

Artikel-Nr. MM10000002



TECHNISCHE DATEN

Abmessungen:	120x300mm (BxTxH)
Werkstoff:	Aluminium, eloxiert E6/EV1
Farbe:	silber
Befestigungsmaterial:	2 x Senkschraube M8x20 A2 4 x Senkschraube M5x25 A2
Gewicht:	ca. 2,3kg

ABMESSUNGEN

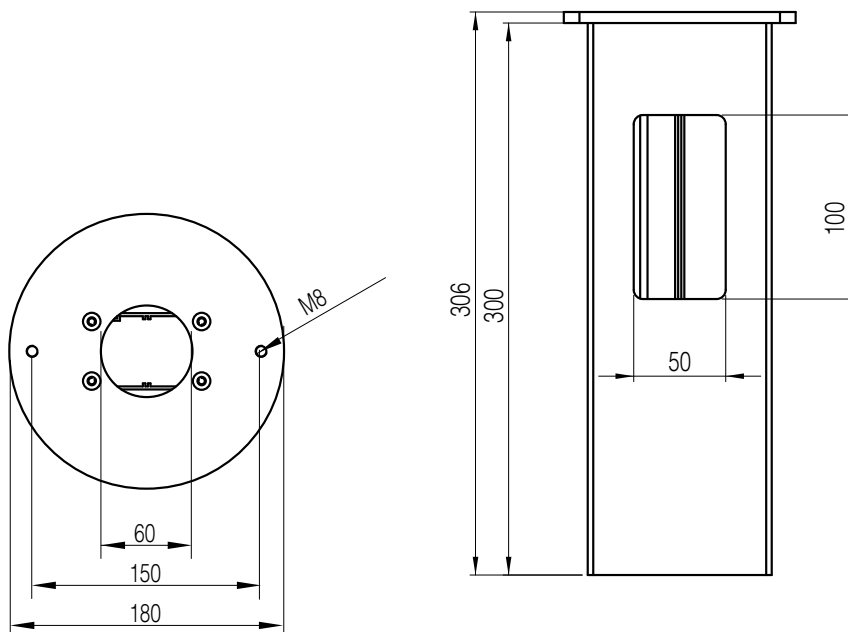

Alle Maße in Millimeter.