



PRODUKTDATENBLATT

SEITE 1/1

MS18 Fußplatte

Artikel-Nr. MD10100002C

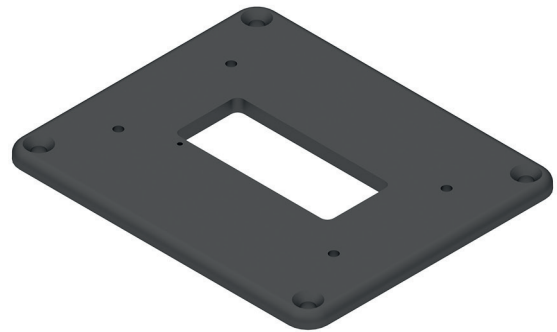

TECHNISCHE DATEN

Abmessungen:	240x200x10mm (BxTxH)
Werkstoff:	Aluminium, eloxiert E6/EV1
Farbe:	anthrazit
Befestigungsmaterial:	4 x Schraube M6x30 A2 (zur Befestigung der Fußplatte am Säulenprofil) 4 x Spanplattenschraube M8x60 A2 4 x Dübel S12
Gewicht:	ca. 1,1kg

ABMESSUNGEN

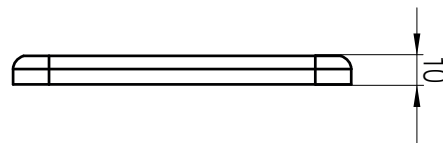
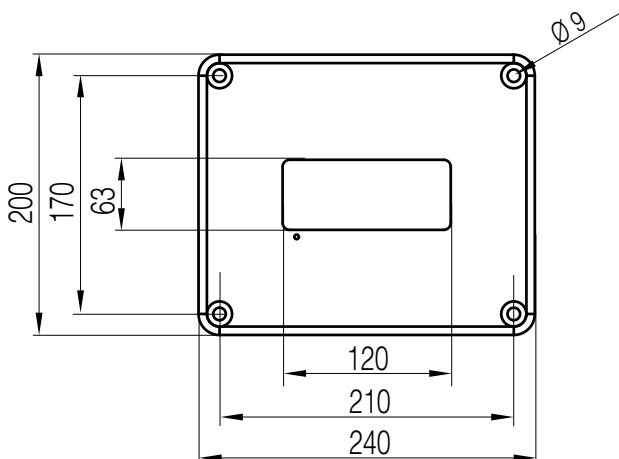

Alle Maße in Millimeter.